

# Technical Data

## Shredder | Series | MZA 4800

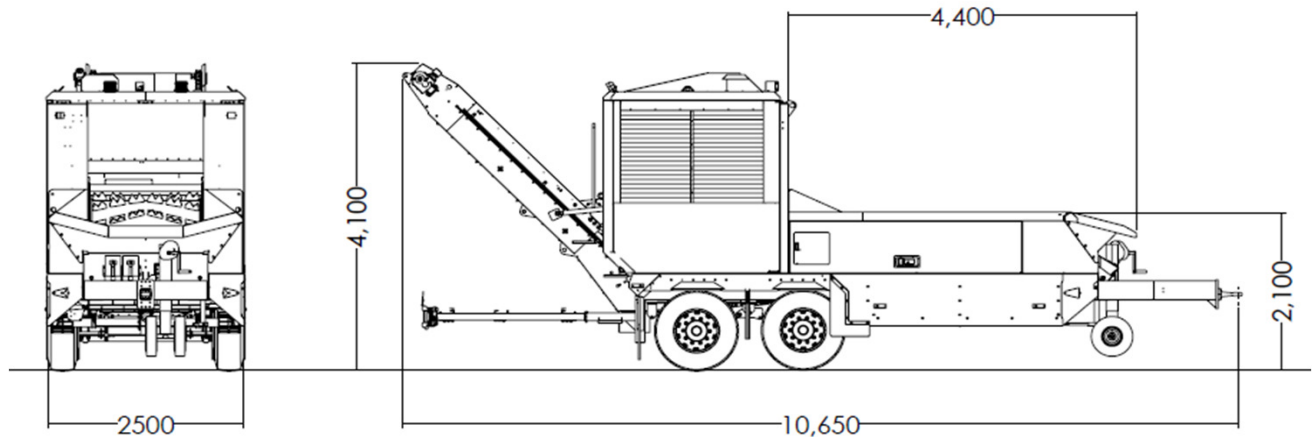

<b>Transport Dimension</b>	l/w/h	10650/2500/4000
<b>Engine</b>		
Manufacturer		MAN
Type		D2676 LE 124
maximum Performance	kw/HP	353/480
Cylinder quantity		R6
Capacity	cc	12419
Nominal rotation Speed	rpm	1750 / 1900
Rotation Speed at maximum Torque	rpm	1200
maximum Torque	Nm	2250
Emission		STAGE III B
Fuel capacity (series/ secondtank small/big)	ltr	500 / 200 / 380
AdBlue capacity	ltr	70
<b>Carriage</b>		2-axle-central carriage, for 80 km/h according to StVZO
Permissible Total Weight	kg	19000
<b>Rotor</b>		
Weight equipped	kg	approx. 1300
Width	mm	1465
Diameter	mm	1000
Rotation Speed at low / high Engine Speed	rpm	1200 / 1300
Flails	piece	loose 48
Milling Strips	piece	8
Flail weight	kg	approx. 3,5
maximum Infeed height	mm	700
<b>Endless Floor and Infeed Roller</b>	#	various rotations between 10%-100%
<b>Rakes</b>	#	position adjustable 0% (small grain) 100% (big grain)
<b>Discharge Conveyor</b>		
Dropping Height (short / long)	mm	3400 / 4000
Width	mm	1450
Speed	m/s	maximum 1,4
<b>Crawler Drive</b>		
Speed	m/s	0,1

Subject to changes of technical data.

There can be dimensions and designations that do not meet to the standard series.

Coping and reprinting only with our permission.

## Shredder | Series | MZA 4800

### Throughput

Green Waste	m <sup>3</sup> /h	up to 180
Matured Timber	m <sup>3</sup> /h	up to 120
Matured Timber (already fractured)	m <sup>3</sup> /h	up to 200
Bark	m <sup>3</sup> /h	up to 230

### Configuration

hydr. Hood Opening	#	●
One-piece side Door		●
Air brake system, with ABS		●
Drawbar Eye (diameter 50mm)		●
Load Sensing hydraulic system		●
Big Storage Compartment		●
24 Voltage Lighting System, according to StVZO		●
Discharge Conveyor short	#	◦
Discharge Conveyor long	#	◦
Magnetic Separator		◦
Crawler Track	#	◦
Crawler Drive	#	◦
Remote Control		◦
Central Lubrication		◦
hydr. Axle Extractor	#	◦
hydr. Support Wheel	#	◦
Reversible Fan	#	◦
Working Lights (3 pieces)	#	◦
Water Spray System		◦
hydr. foldable extended (700mm) hopper	#	◦
hydr. or manual foldable extended side walls	#	◦
Fine Crushing		◦
available size of screens: 30,40,50,60,70		◦
Vialis Rake		◦
Drawbar Eye Extension		◦
Special Paint		◦
Biological Oil		◦
Volume Measurement by optical Scale System Mounted on Discharger		◦
Secondtank		◦
Diesel Particulate Filter		◦
Soundproofing Package		◦

- series
- option

all positions pointed out with # can be operate by optional remote control